



**BREM**

## Radiateurs pour l'architecture

Radiateurs, sèche-serviettes et accessoires  
conçus et fabriqués en Italie

UPDATES **26**

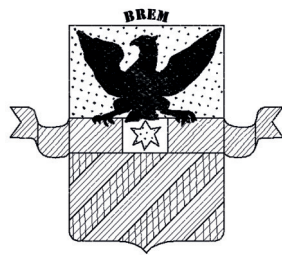

# UPDATES **26**

**AIR**

---

49

**CHEM**

---

9

**CROSS**

---

59

**DUO**

---

37

**GEO**

---

21

**GUEST**

---

27

**HAND**

---

33

**LAME**

---

53

**RAW**

---

41

**VELETTA**

---

45

**SISTEMI WI-FI**

---

63



La gamma Brem è disponibile in oltre 100 colori fra:

- Colori RAL;
- Brillanti, satinati, opachi e soft touch;
- Metallizzate (brillanti e satinati);
- Sablé;
- Finiture speciali;
- Colori e finiture custom;
- Verniciature a effetto galvanico.

*La gamme Brem est disponible dans plus de 100 couleurs, parmi lesquelles:*

- *Couleurs RAL;*
- *Brillantes, satinées, mates et soft touch;*
- *Métallisées (brillantes et satinées);*
- *Sablées ;*
- *Finitions spéciales ;*
- *Couleurs et finitions personnalisées;*
- *Peintures effets galvaniques.*

*The Brem range is available in over 100 colors, including:*

- *RAL colors;*
- *Glossy, satin, matte, and soft touch;*
- *Metallic (glossy and satin);*
- *Sablé;*
- *Special finishes;*
- *Custom colors and finishes;*
- *Painting with galvanic reproduction.*

**VERNICIATURE A EFFETTO GALVANICO - novità 2026**  
**PEINTURES EFFETS GALVANIQUES - nouveauté 2026**  
**PAINTING WITH GALVANIC REPRODUCTION - 2026 news**



Oro spazzolato satinato  
*Or brossé satinée*  
*Satin brushed gold*



Bronzo spazzolato satinato  
*Bronze brossé satinée*  
*Satin brushed bronze*

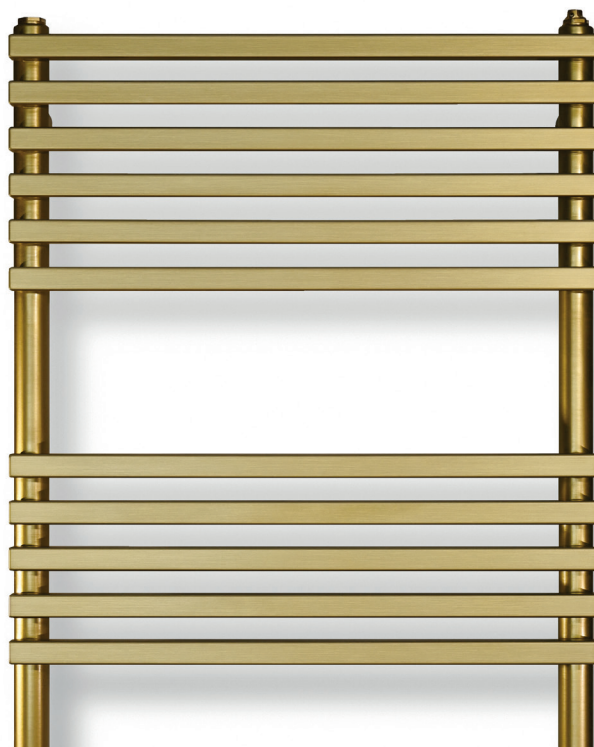

Canna di fucile spazzolato satinato  
*Gun metal brossé satinée*  
*Satin brushed gun metal*



Nichel spazzolato satinato  
*Nickel brossé satinée*  
*Satin brushed nickel*



Rame spazzolato satinato  
*Cuivre brossé satinée*  
*Satin brushed copper*

Verniciatura a effetto galvanico bronzo spazzolato.  
*Peinture effet galvanique bronze brossé.*  
*Brushed bronze painting with galvanic reproduction.*



MAHN-AIR 112-51

**BREM**

# TABELLA DI SINTESI

## TABLEAU RÉCAPITULATIF

### SUMMARY TABLE

<b>H</b> cm <small>min max</small>	<b>L</b> cm <small>min max</small>
88 198	12 32
<b>P</b> cm <small>min max</small>	<b>W</b> att <small>min max</small>
32 41,5	250 800

È lo strumento di consultazione che offre una panoramica rapida di dimensioni e rese termiche coperte da una collezione.

**H, L, P:** range di altezze, larghezze, profondità minime e massime, inclusi gli attacchi a parete.

**W:** range di rese termiche minime e massime, espresse in Watt.

*Simple outil de consultation rapide pour les dimensions et les puissances thermiques d'une collection.*

**H, L, P:** gamme de hauteurs, largeurs et profondeurs minimales et maximales, y compris les fixations murales.

**W:** gamme de puissances thermiques minimales et maximales, exprimés en watts.

*It is a reference tool that provides a quick overview of the sizes and heat outputs covered by a collection.*

**H, W, D:** range of minimum and maximum heights, widths and depths, including wall brackets.

**W:** range of minimum and maximum heat outputs, expressed in watts.



#### **CALORIFERO**

Soluzioni studiate per offrire alte rese termiche.

#### **RADIATEUR**

*Solutions conçues pour offrir un puissances thermique élevé.*

#### **RADIATOR**

*Solutions designed to offer high thermal efficiency.*



#### **SCALDASALVIETTE**

Complemento ideale per il bagno, riscalda e asciuga.

#### **SÈCHE-SERVIETTES**

*Complément idéal pour la salle de bain, il chauffe et sèche.*

#### **TOWEL WARMER**

*The ideal bathroom accessory, it heats and dries towels.*



Funzionamento idraulico.

*Chauffage hydraulique.  
Hydraulic operation.*



Funzionamento elettrico.

*Chauffage électrique.  
Electrical operation.*



**CHEM**

Il fascino dell'industria  
*Le charme de l'industrie*  
*The charm of industry*

<b>H</b> cm <small>min max</small>	<b>L</b> cm <small>min max</small>
96 256	9 93
<b>P</b> cm <small>min max</small>	<b>W</b> att <small>min max</small>
18	138 3407

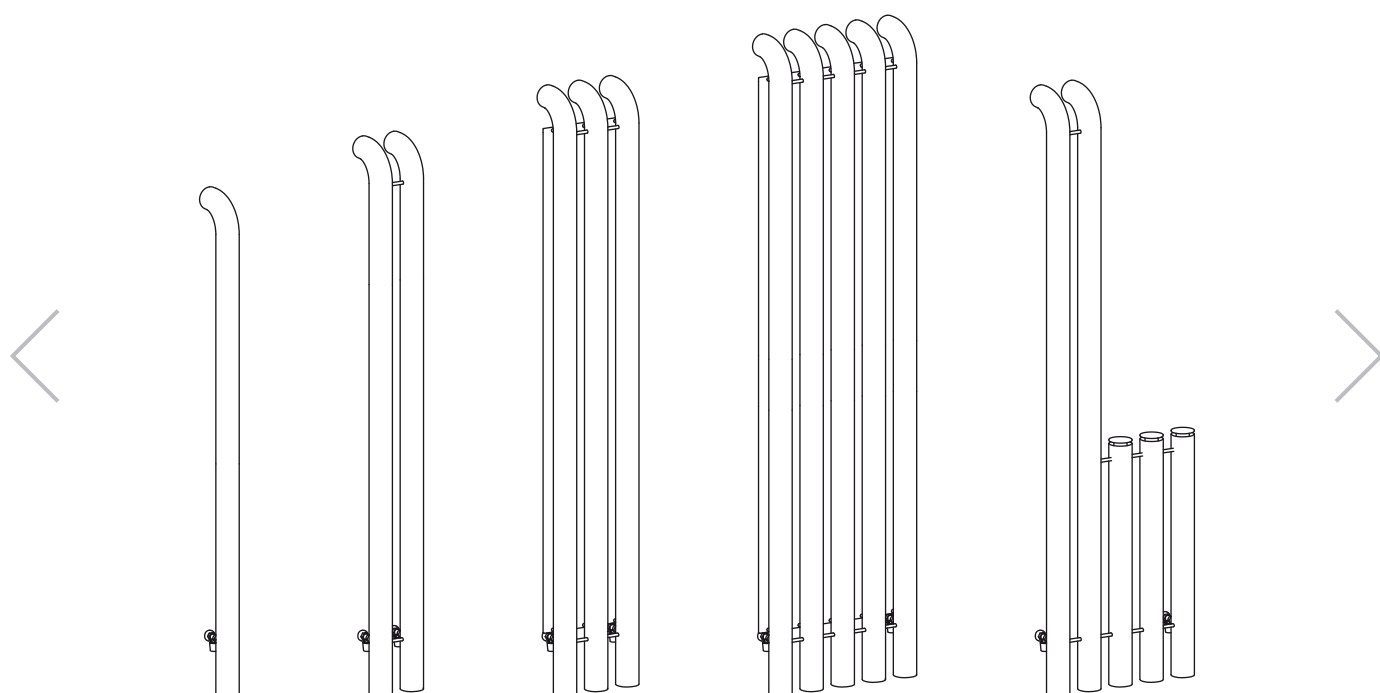

# CHEM

design: Davide Diliberto



Chem è un sistema di radiatori disegnato per ricreare il fascino degli impianti industriali. L'elemento base è un tubo di 9 cm di diametro, che attraversa la stanza dal pavimento alla parete.

*Chem est un système de radiateurs conçu pour recréer le charme des installations industrielles. L'élément de base est un tube de 9 cm de diamètre qui traverse la pièce du sol au mur.*

*Chem is a radiator system designed to recreate the charm of industrial installations. The basic element is a 9 cm diameter pipe that crosses the room from floor to wall.*



CHEM 216-2/96-3



CHEM 216-3



CHEM 256-3



CHEM 236-2

**BREM**

13



CHEM-M  
Dettaglio del gancio alto.  
*Détail des patères hauts.*  
Detail of the high hook.



<b>H</b> cm <small>min max</small>	<b>L</b> cm <small>min max</small>
196 236	40 68
<b>P</b> cm <small>min max</small>	<b>W</b> att <small>min max</small>
18	300 1230

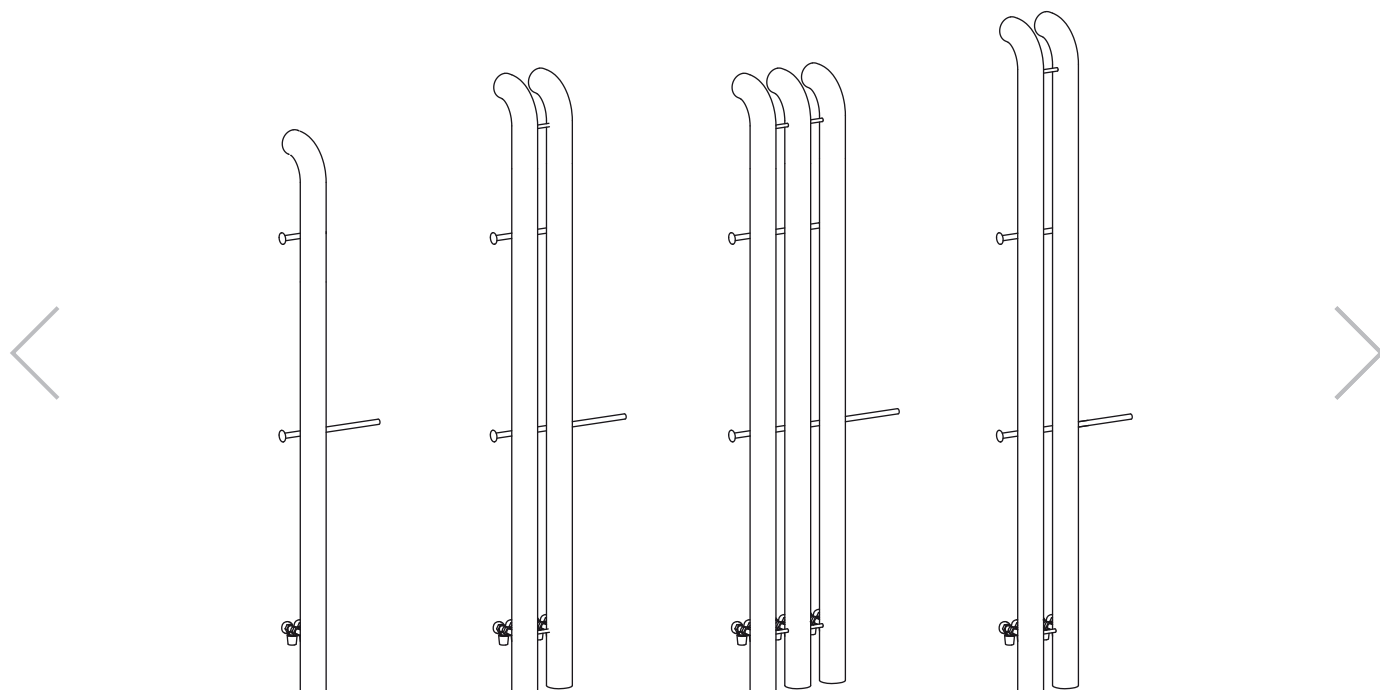

# CHEM-M

design: Davide Diliberto



Le versioni Chem-M uniscono purezza formale e praticità. Le due barre con ganci permettono di appendere comodamente asciugamani e accappatoi da entrambi i lati.

*Les versions Chem-M allient pureté formelle et fonctionnalité. Les deux barres avec pignoirs permettent d'accrocher facilement des serviettes et des patères des deux côtés.*

*The Chem-M versions combine formal purity and practicality. The two bars with hooks allow towels and bathrobes to be hung conveniently on both sides.*

CHEM-S 216-50-3



CHEM-S 216D-50-3

<b>H</b> cm <small>min max</small>	<b>L</b> cm <small>min max</small>
196 216	50 60
<b>P</b> cm <small>min max</small>	<b>W</b> att <small>min max</small>
18	400 1200

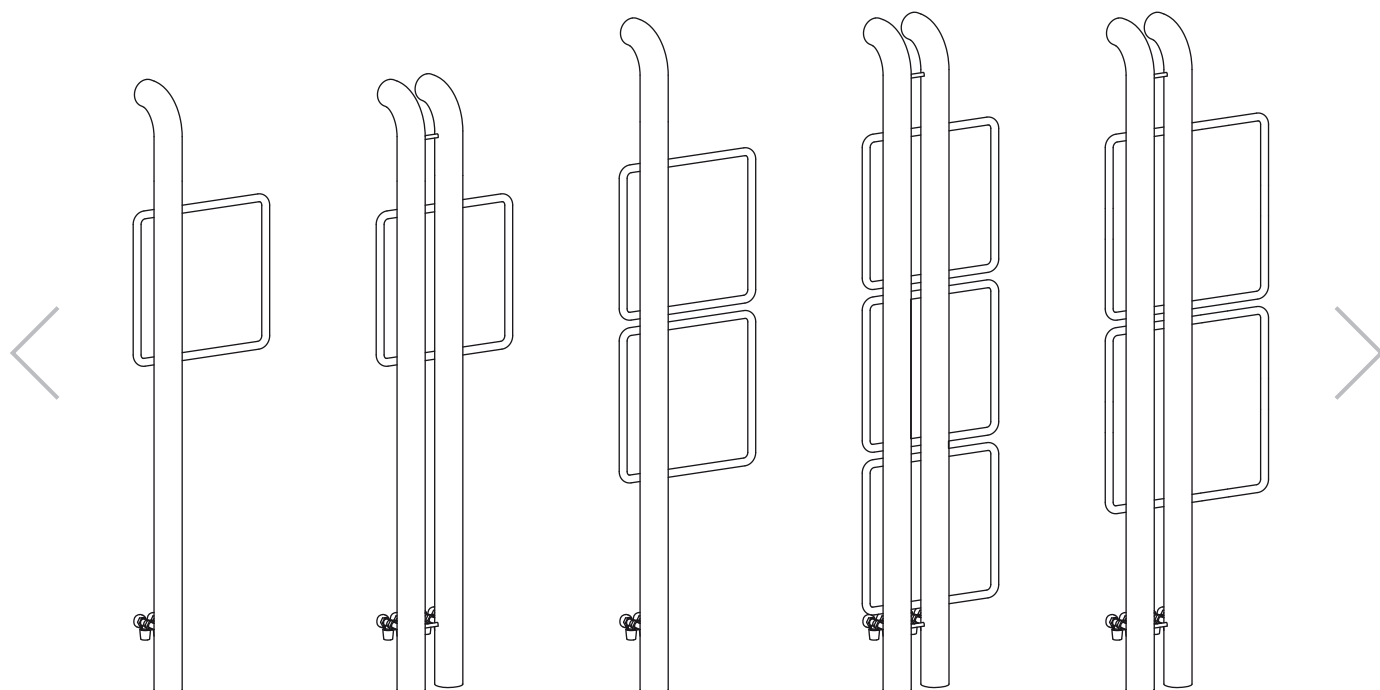

# CHEM-S

design: Davide Diliberto



Le versioni scaldaserviette della collezione Chem conservano il riferimento agli ambienti industriali. I moduli quadrati aumentano la praticità con una originale estetica asimmetrica.

*Les versions sèche-serviettes de la collection Chem conservent la référence aux environnements industriels. Les modules carrés augmentent la praticité avec une esthétique asymétrique originale.*

*The towel warmer versions of the Chem collection retain their industrial feel. The square modules increase practicality with an original asymmetrical aesthetic.*



CHEM-S 216-50-1

CHEM-S 216D-60-2



CHEM-S 216-50-2

An abstract geometric composition featuring a large, dark gray circle on the right side, partially overlapping a horizontal bar that spans the width of the image. The bar is divided into three horizontal sections: a light gray top section, a dark gray middle section, and a light gray bottom section. The background is a light gray gradient.

# GEOMETRICA

Composizioni visive  
*Compositions visuelles*  
*Visual compositions*

<b>H</b> cm <small>min max</small>	<b>L</b> cm <small>min max</small>
54 87	56 143
<b>P</b> cm <small>min max</small>	<b>W</b> att <small>min max</small>
12	300 800

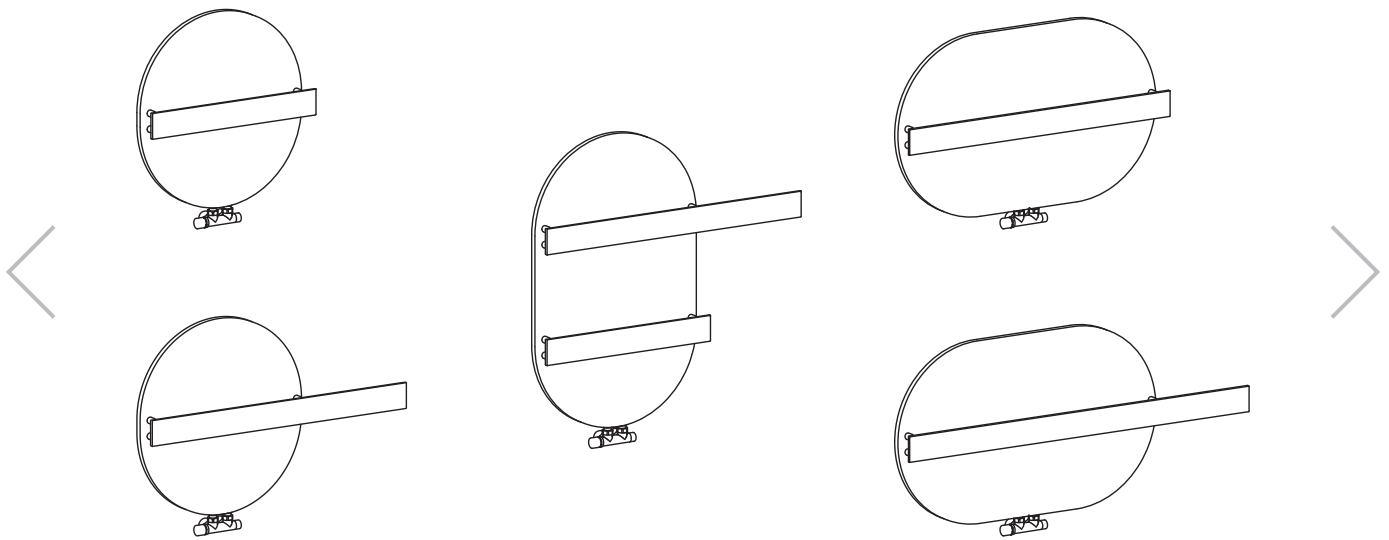

# GEO-T / GEO-O

design: Luigi Brembilla



La collezione Geometrica abbina tutte le varianti di cerchio e ovale ad un pratico maniglione portasalviette. Un complemento compatto, decorativo e funzionale.

*La collection Geometrica combine toutes les variantes de cercle, ovale, carré et rectangle avec une barre porte-serviettes pratique. Un accessoire compact et fonctionnel.*

*The Geometrica collection combines all the circle, oval, square and rectangle variants with a practical towel rail. A compact and functional accessory.*

GEO-OV 87-87



GEO-O 54-89





GEO-T 58-56

**BREM**

23

GEO-RV 87-56



GEO-Q 58-87

**BREM**

24

<b>H</b> cm <small>min max</small>	<b>L</b> cm <small>min max</small>
58 87	56 154
<b>P</b> cm <small>min max</small>	<b>W</b> att <small>min max</small>
12	400 962

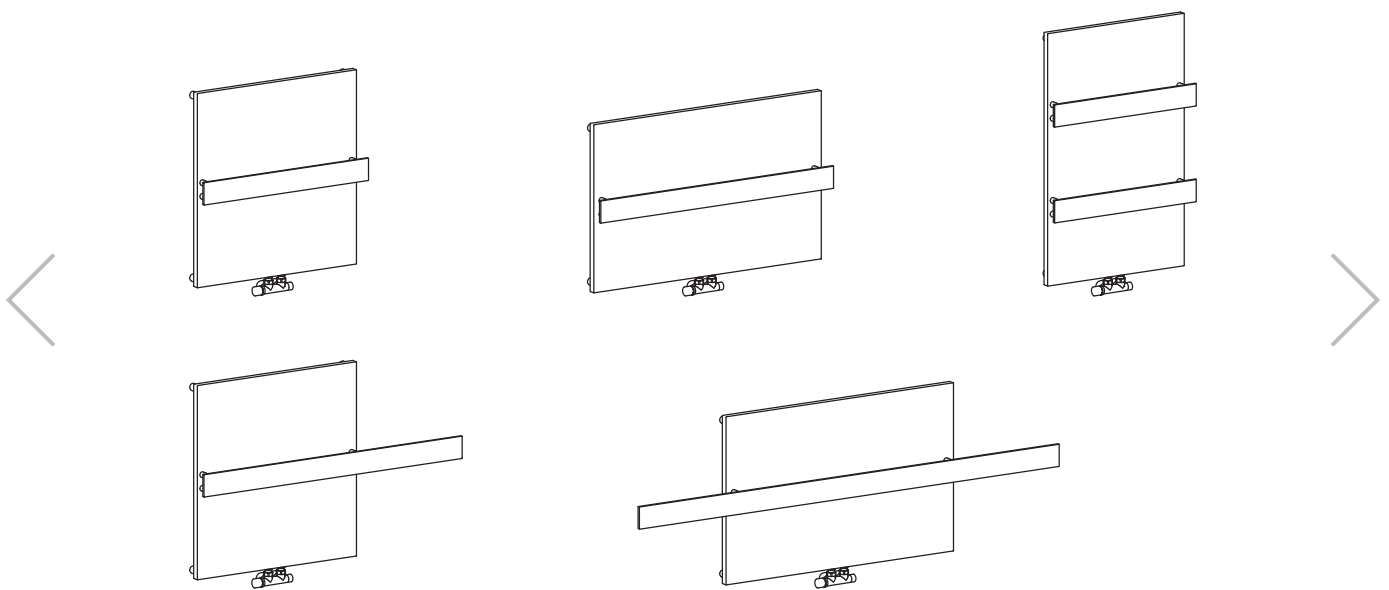

# GEO-Q / GEO-R

design: Luigi Brembilla



La collezione si completa delle varianti quadrate e rettangolari. Mantiene la praticità del maniglione portasalviette con forme più rigorose che si fondono con l'ambiente.

*La collection est complétée par des variantes carrées et rectangulaires. Elle conserve la praticité de la barre porte-serviettes avec des formes plus rigoureuses qui se fondent dans l'environnement.*

*The collection is completed by square and rectangular versions. It retains the practicality of the towel rail with more rigorous shapes that blend in with the environment.*



## GUEST

Oggetto multifunzionale  
*Objet multifunctionnel*  
*Multifunctional item*



<b>H</b> cm <small>min max</small>	<b>L</b> cm <small>min max</small>
88 198	12 32
<b>P</b> cm <small>min max</small>	<b>W</b> att <small>min max</small>
42	250 800

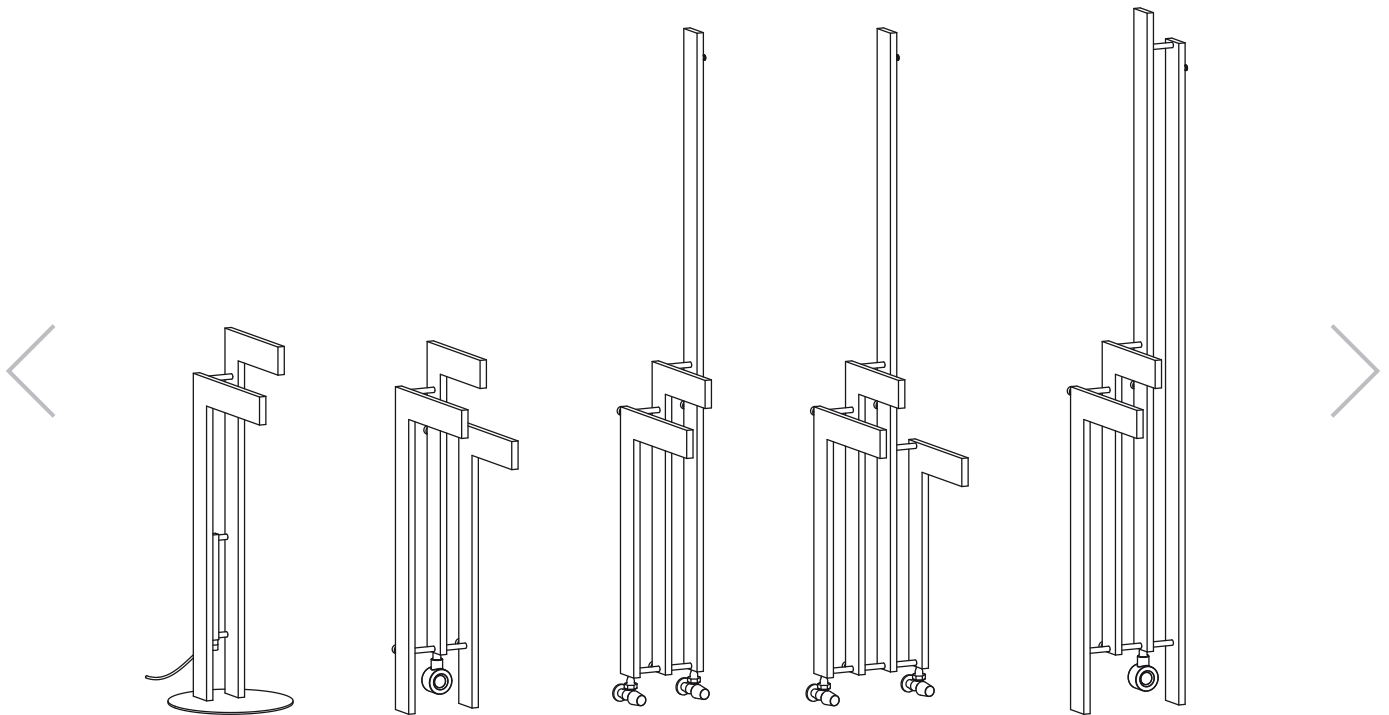

# GUEST

design: Davide Diliberto



Guest è uno scaldasalviette che sostituisce i tradizionali accessori porta asciugamani. Un accessorio salvaspazio disponibile anche elettrico e freestanding.

*Guest est un sèche-serviettes qui remplace les accessoires traditionnels pour suspendre les serviettes. Un accessoire peu encombrant, également disponible en version électrique et autoportante.*

*Guest is a towel warmer that replaces traditional towel rails. A space-saving accessory also available in electric and freestanding versions.*



GUEST 104-22



GUEST 182-22

**BREM**

29



GUEST-A 104-12

**BREM**

30





# HAND

Calore lineare  
*Chaleur linéaire*  
*Linear heat*

<b>H</b> cm <small>min max</small>	<b>L</b> cm <small>min max</small>
8 123	8 123
<b>P</b> cm <small>min max</small>	<b>W</b> att <small>min max</small>
7	30 75

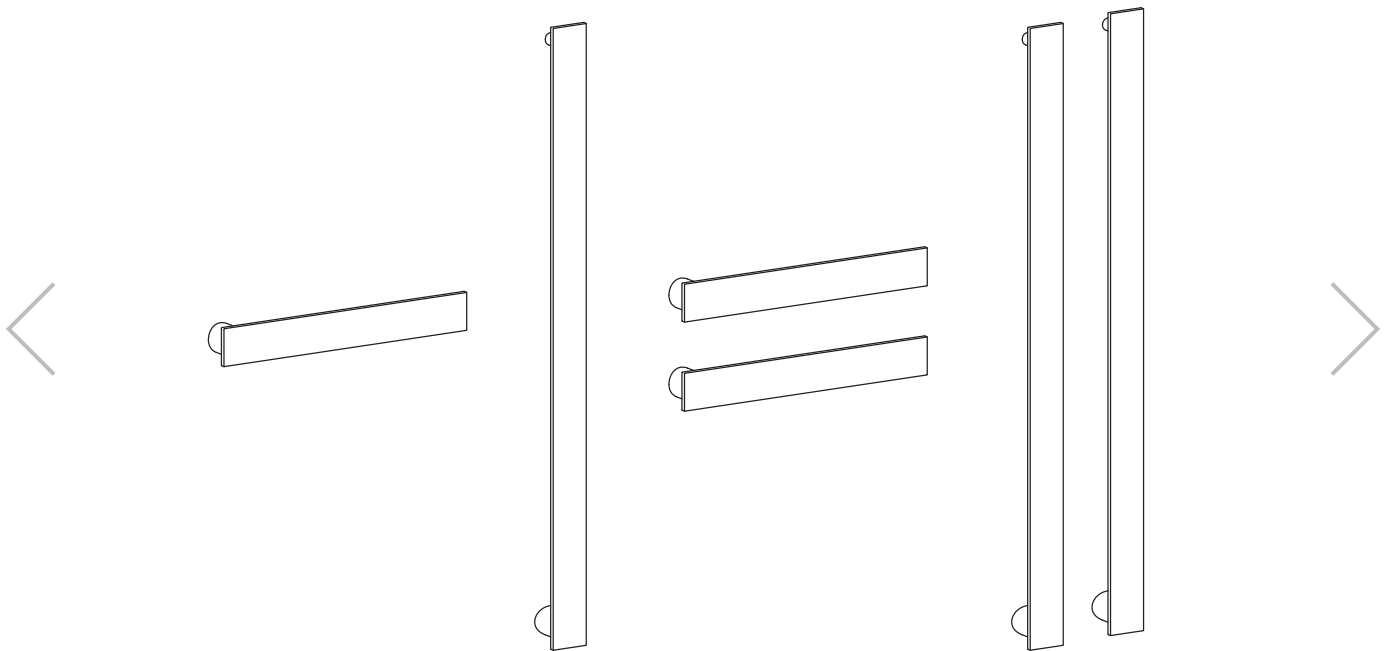

# HAND

design: Luigi Brembilla



L'essenza dello scaldasalviette: Hand è un elemento piatto, spesso solo 1 cm, installabile sia in orizzontale che verticale con alimentazione esclusivamente elettrica.

*L'essence même du sèche-serviettes: Hand est un élément plat, d'une épaisseur de seulement 1 cm, qui peut être installé aussi bien à l'horizontale qu'à la verticale, avec un chauffage exclusivement électrique.*

*The essence of the towel warmer: Hand is a flat element, only 1 cm thick, which can be installed either horizontally or vertically and is powered exclusively by electricity.*

> Verniciatura a effetto galvanico nichel spazzolato.  
*Peinture effet galvanique nickel brossé.*  
*Brushed nickel painting with galvanic reproduction.*



e.HAND 8-55





e.HAND 123-8



## DUO

Simmetria e leggerezza  
*Symétrie et légèreté*  
*Symmetry and lightness*

<b>H</b> cm <small>min max</small>	<b>L</b> cm <small>min max</small>
101 133	44 59
<b>P</b> cm <small>min max</small>	<b>W</b> att <small>min max</small>
8,2	486 900

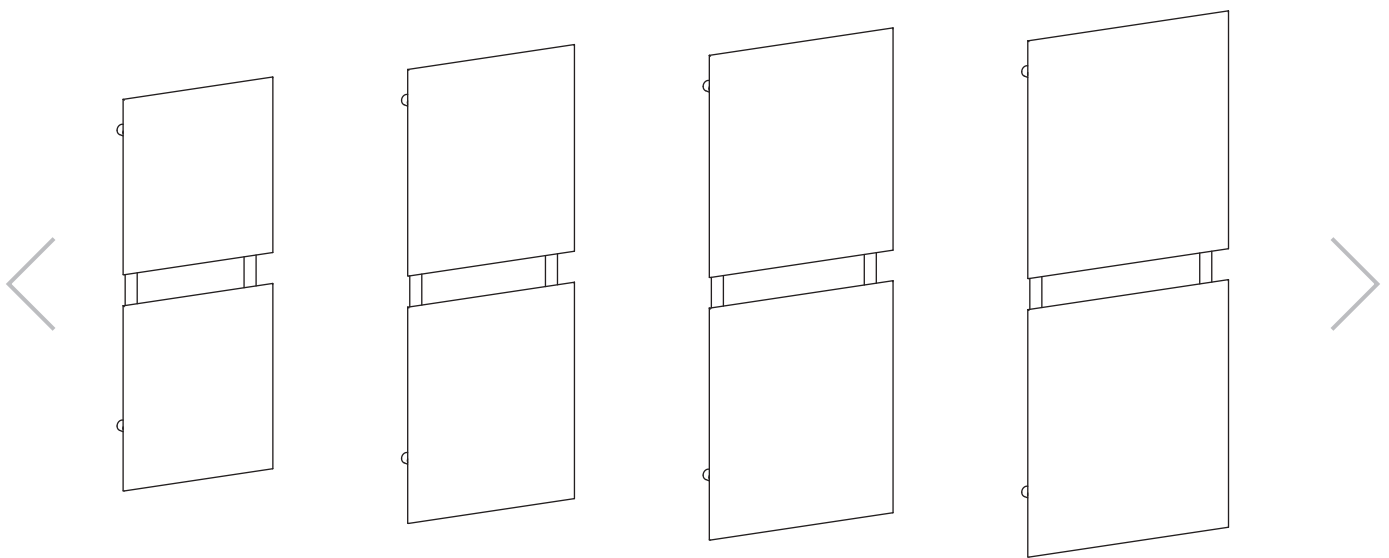

# DUO

design: Luigi Brembilla



Simmetria, leggerezza e valvole nascoste. Duo è disegnato con piastre radianti poco più spesse di 2 cm, che appaiono ancor più sottili grazie ai bordi rastremati. Disponibile con piastre e collettori bicolor.

*Symétrie, légèreté et vannes cachées. Duo est conçu avec des plaques radiantes d'un peu plus de 2 cm d'épaisseur, qui semblent encore plus fines grâce à leurs bords effilés. Disponible avec des plaques et des collecteurs bicolores.*

*Symmetry, lightness and concealed valves. Duo is designed with radiant plates that are just over 2 cm thick, which appear even thinner thanks to their tapered edges. Available with two-tone plates and manifolds.*



DUO

La cornice rastremata permette di nascondere le valvole.

*Le cadre effilé permet de dissimuler les valves.*

*The tapered frame allows the valves to be concealed.*

e.DUO 117-49



**BREM**

38



DUO 117-49

**BREM**

39



**RAW**

Architettura a nudo  
*Architecture à nu*  
*Architecture laid bare*



<b>H</b> cm <small>min max</small>	<b>L</b> cm <small>min max</small>
50 210	50 157
<b>P</b> cm <small>min max</small>	<b>W</b> att <small>min max</small>
13,5	287 1200

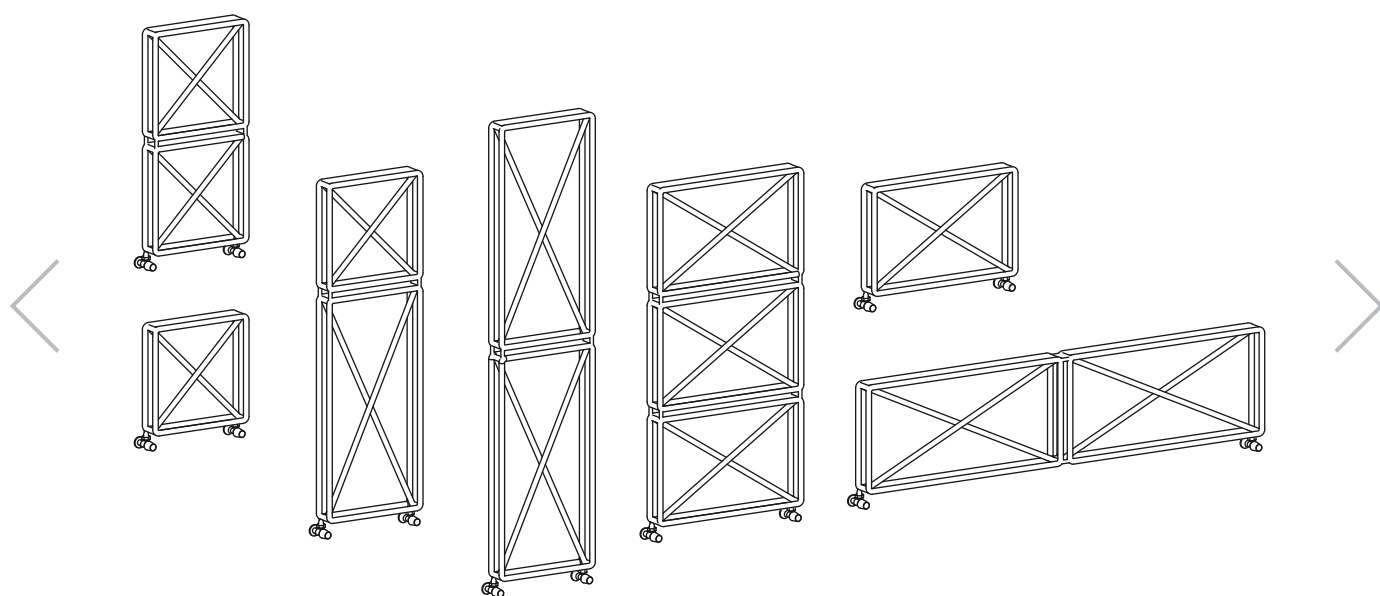

# RAW

design: Davide Diliberto



La collezione Raw trasforma il radiatore in un elemento tridimensionale, vuoto e leggero. L'incrocio dei tubi cita elementi da costruzione come impalcature e tralicci, per dialogare con l'architettura in modo diretto e non convenzionale.

*La collection Raw transforme le radiateur en un élément tridimensionnel, vide et léger. Le croisement des tubes fait référence à des éléments de construction tels que les échafaudages et les poutres, pour dialoguer avec l'architecture de manière directe et non conventionnelle.*

*The Raw collection transforms the radiator into a three-dimensional, hollow and lightweight element. The intersection of the pipes references construction elements such as scaffolding and trusses, interacting with the architecture in a direct and unconventional way.*

RAW2 157-50B



RAW3 210-50B RAW2 210-50 RAW2 50-157B



RAW3 50-157

**BREM**

43



## VELETTA

Una piega inaspettata  
*Un pli inattendu*  
*An unexpected fold*

2022 TOP DESIGN  
**EUROPEAN  
PRODUCT  
DESIGN  
AWARD**

<b>H</b> cm <small>min max</small>	<b>L</b> cm <small>min max</small>
135 175	42 50
<b>P</b> cm <small>min max</small>	<b>W</b> att <small>min max</small>
18,5 22,5	650 1200

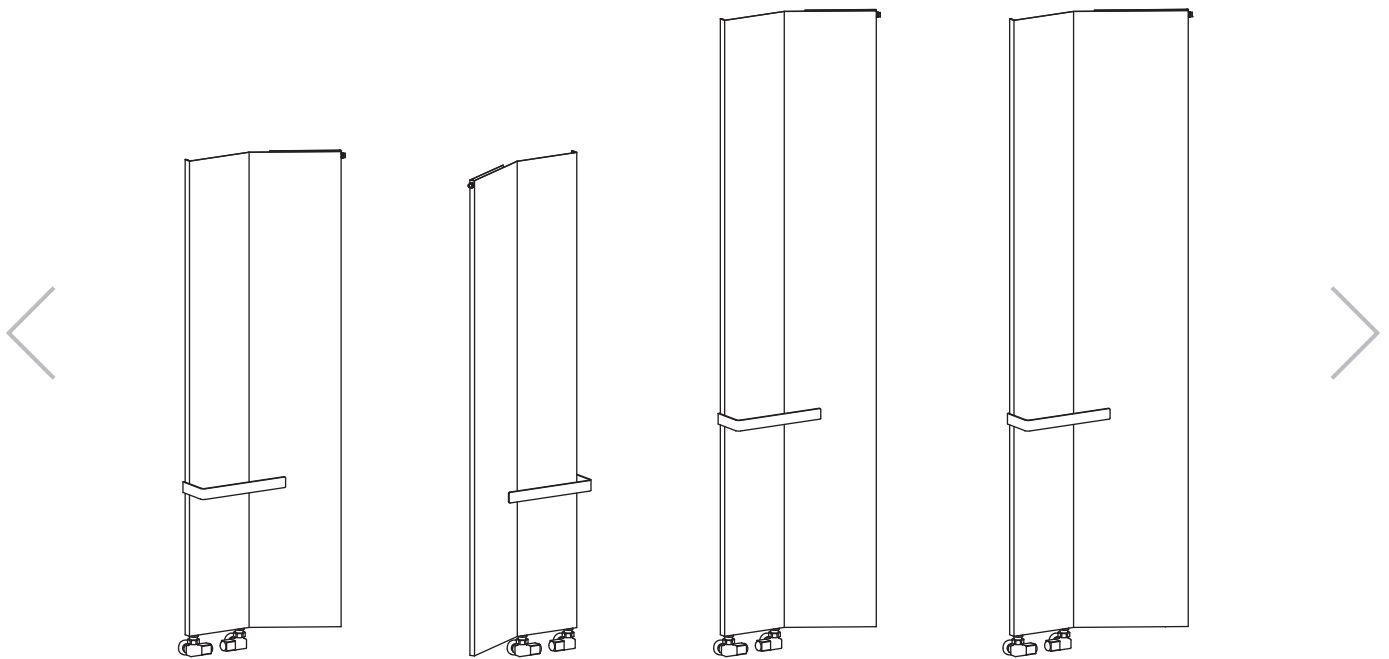

# VELETTA

design: Davide Diliberto



Una piastra divisa da una piega netta e un'ala che si allontana dal muro: Veletta consente di nascondere alla vista accappatoi e asciugamani per il corpo. Una sorta di parete attrezzata che asciuga e riscalda.

*Une plaque divisée par un pli net et une aile qui s'éloigne du mur: Veletta permet de cacher les peignoirs et les serviettes de bain. Une sorte de paroi équipée qui sèche et réchauffe.*

*A panel divided by a sharp fold and a wing that extends away from the wall: Veletta allows you to hide bathrobes and towels from view. A sort of wall unit that dries and warms.*



VELETTA  
Dettaglio degli appendini magnetici ARC.  
*Détail des cintres magnétiques ARC.*  
*Detail of the ARC magnetic hangers.*



VELETTA 175-50



VELETTA 175-50

**BREM**

47



**AIR** COLLECTION

Spazio alla leggerezza  
*Place à la légèreté*  
*Make way for lightness*

MAHN-AIR  
PLANK-AIR  
PLUS-AIR  
SHAR-AIR

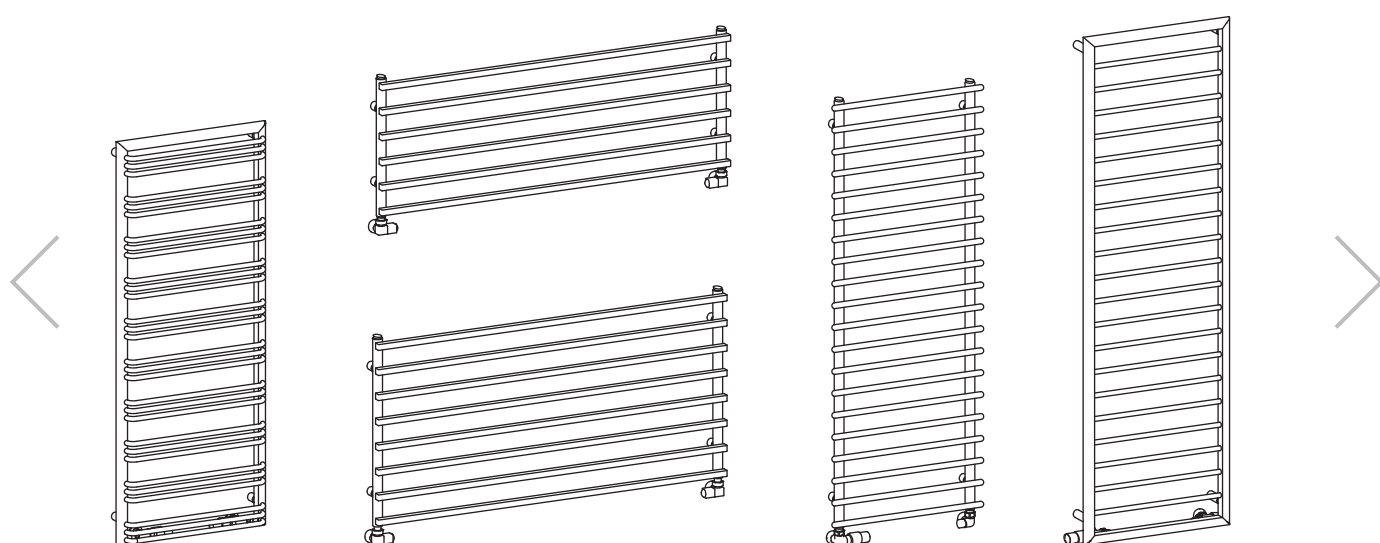

# AIR COLLECTION

TubiDESIGN



L'ampia distanza fra i tubi caratterizza la gamma di scaldasalviette Air. Questa soluzione rende più comodo riporre gli asciugamani, con uno stile pulito, ritmico e leggero.

*La grande distance entre les tuyaux caractérise la gamme de chauffe-serviettes Air. Cette solution rend plus pratique mettre les serviettes, avec un style propre, rythmique et léger.*

*The wide spacing between the tubes characterises the Air range of towel warmers. This solution makes it easier to store towels, with a clean, rhythmic and light style.*

SHAR-AIR A2R 122-50



PLANK-AIR 156-50





Verniciatura a effetto galvanico rame spazzolato.  
*Peinture effet galvanique cuivre brossé.*  
*Brushed copper painting with galvanic reproduction.*



PLUS-AIR 171-52



**LAME** COLLECTION

Variazioni sul tubo piatto  
*Variations sur le tube plat*  
*Variations on the flat tube*



LAME  
LAME-UP  
REGULAR  
TORRI  
HERG  
SBARRA-UP  
META



LAME SLIM  
LAMATH  
HERG'S  
HERG-OT  
SBARRA  
HOOK  
KUO

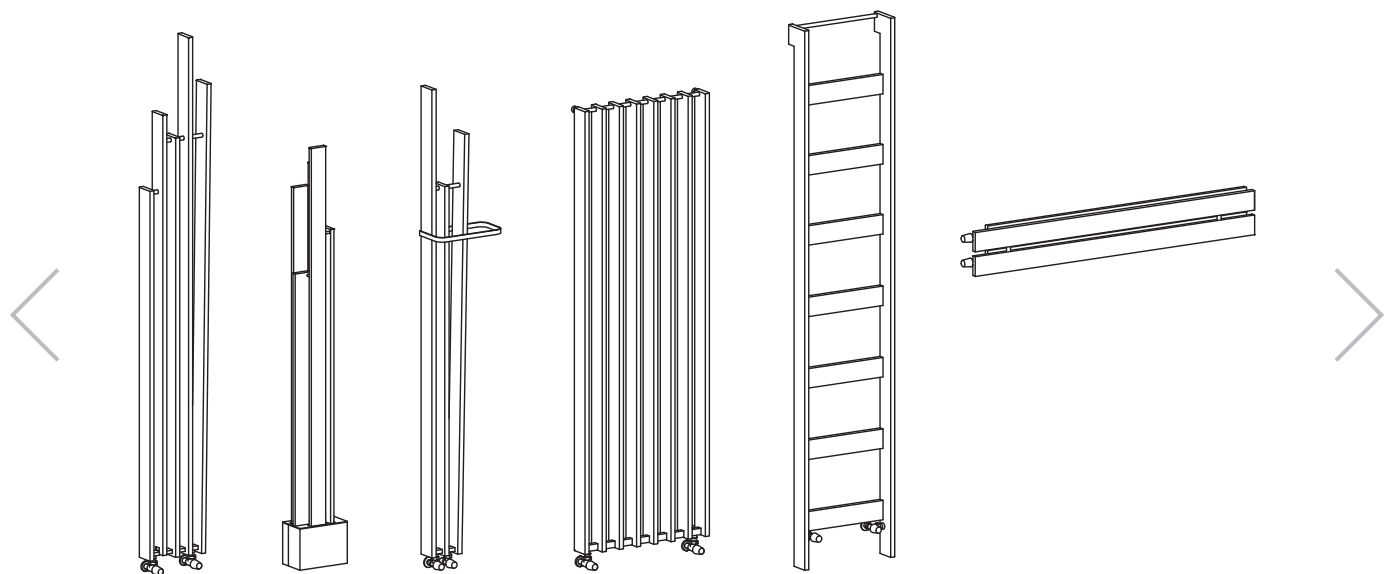

# LAME COLLECTION

Design: Davide Brembilla, Luigi Brembilla, Bettazzi + Percoco



La gamma di radiatori e scaldasalviette Lame si costruisce sul tubo piatto rettangolare in diverse declinazioni. Tutti i modelli si distinguono per minimalismo, ritmo e sapore architettonico.

*La gamme de radiateurs et sèche-serviettes Lame est construite sur un tube plat rectangulaire décliné en différentes versions. Tous les modèles se distinguent par leur minimalisme, leur rythme et leur style architectural.*

*The Lame range of radiators and towel warmers is based on flat rectangular tubing in various configurations. All models are characterised by minimalism, rhythm and architectural flair.*

LAMATH 190-3

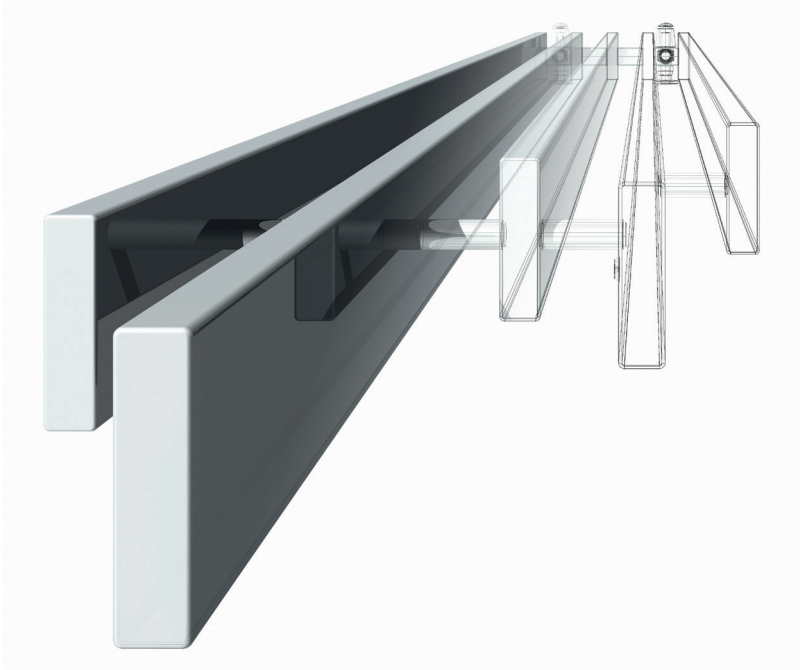

REGULAR 240-50-9



LAME 210-2



LAME-UP 230-6



LAME SLIM  
Dettaglio del maniglione.  
*Détail de la barre.*  
*Detail of the grab bar.*



HERG-ÖT 212-42 HOI



**CROSS** COLLECTION

*Una gamma su misura  
Une gamme sur mesure  
A tailor-made range*



CROSS-Q  
CROSS-G  
CROSS-V



CROSS  
CROSS-CROM  
CROSS-Q  
CROSS-FO/FA  
CROSS-BIC/TRIC  
CROSS-R/RV  
FREE

ESSEN  
QUAR  
PIT  
ASYMM  
ALIS  
KORE  
TRAP

VISION  
ZOOM

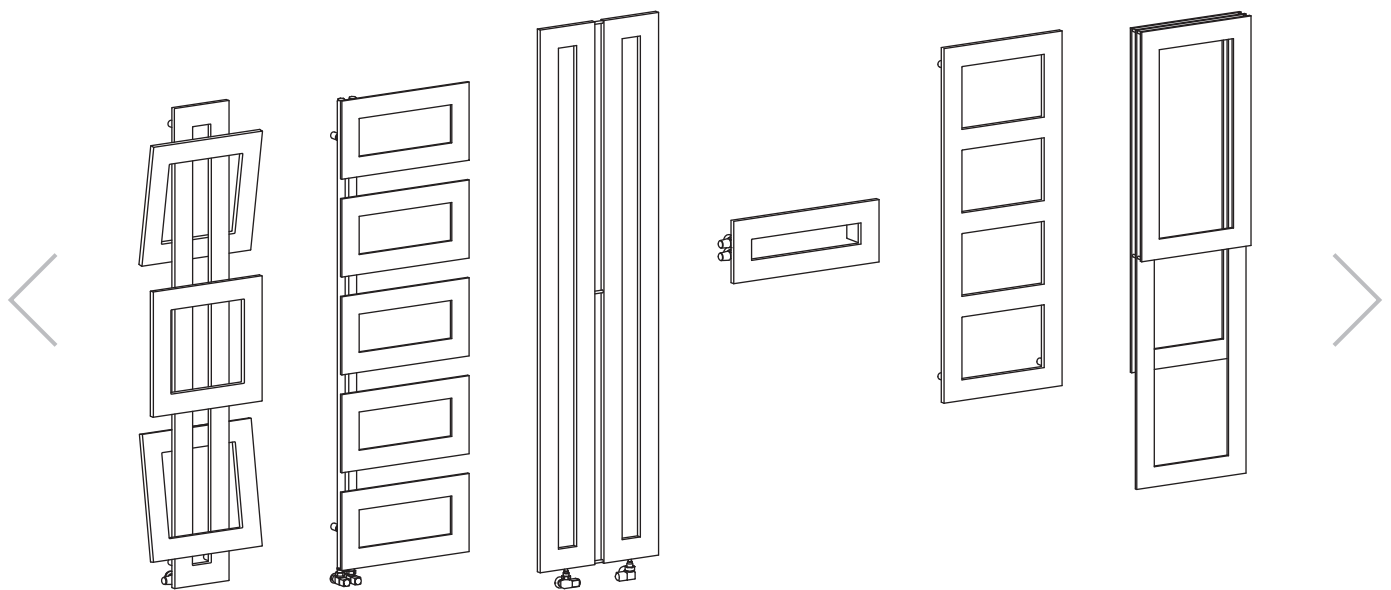

# CROSS COLLECTION

design: Luigi Brembilla, Pietro Facheris



Cross è la gamma più estesa di Brem, una collezione di modelli best seller costruiti su cornici piatte che consente una straordinaria varietà di forme, soluzioni pratiche e rese termiche.

*Cross est la gamme la plus étendue de Brem, une collection de modèles best-sellers construits sur des cadres plats qui offrent une extraordinaire variété de formes, de solutions pratiques et de puissances thermiques.*

*Cross is Brem's most extensive range, a collection of best-selling models built on flat frames that allow for an extraordinary variety of shapes, practical solutions and thermal performance.*

CROSS 88-120

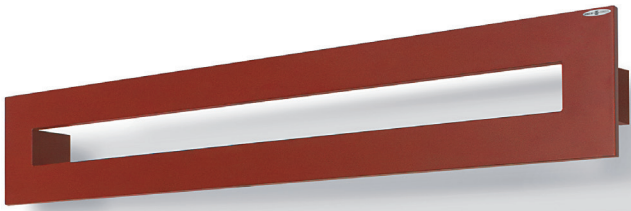

FREE 24-144



ASYMM 145-56



CROSS 152-56

**BREM**

61



e.GUEST-A 104-22



e.VISION-1 ST 128-56

Con copricavo  
Avec cache-câble  
With cable cover

Il KIT ELY WiFi permette di gestire da remoto, tramite l'applicazione gratuita, la temperatura fino a 16 radiatori elettrici contemporaneamente. Comprende base di ricarica e piastra di fissaggio a muro.

*Le KIT ELY WiFi permet de gérer à distance, via l'application gratuite, la température de 16 radiateurs électriques simultanément.*

*Il comprend une base de recharge et une plaque de fixation murale.*

*The ELY WiFi KIT allows you to remotely manage the temperature of up to 16 electric radiators simultaneously via the free app.*

*Includes charging base and wall mounting plate.*



Compatible with

Google Assistance





# SISTEMI WI-FI

## Systèmes WI-FI - WI-FI systems



Grazie alla gamma di accessori Brem, è possibile programmare e regolare anche da remoto ogni impianto di riscaldamento: centralizzato o autonomo, idraulico o elettrico.

Grâce à la gamme d'accessoires Brem, il est possible de programmer et de régler à distance n'importe quel système de chauffage: centralisé ou autonome, hydraulique ou électrique.

Thanks to the range of Brem accessories, it is possible to programme and adjust any heating system remotely: centralised or independent, hydraulic or electric.

Direzione creativa / Direction créative / Creative direction:  
Davide Diliberto



Foto in bianco e nero / Photos en noir et blanc / B&W photo:  
Luigi Ferraro, Fabio Enrico Viganò

© BREM  
Tutti i diritti riservati / Tous droits réservés / All rights reserved  
Printed in Italy, 04/2026



Scarica la versione digitale.  
*Télécharger la version numérique.*  
Download the digital version.

**BREM srl**

Via dell'Artigianato, 8  
24046 Osio Sotto, Bergamo - Italy  
TEL. +39 035 482 36 36  
www.brem.it  
e-mail: brem@brem.it

**BREM France**

Parc Aquatechnique, 2 Rue De Londres  
34200 Sète - France  
TEL. +33 04 67 18 46 48  
www.brem.fr  
e-mail: info@brem.fr

**BREM Export**

www.bremradiators.com  
e-mail: export@brem.it





**brem.fr**

*Designed & Made in Italy*